



WATER RESOURCES AUTHORITY
Accounting for Every Drop!

TENDER NO.: WRA/T/11/2019-2020

**TENDER NAME: CONSTRUCTION OF TWO (2) NO. DJABIA'S AT MATONDONI AND
KIPUNGANI PRIMARY SCHOOLS IN LAMU ISLAND**

Tender Issue Date : 15th April, 2020

Tender Closing Date: 29th April, 2020 At 11.00am

TABLE OF CONTENTS

		<u>PAGE</u>
	INTRODUCTION	1
SECTION I	INVITATION FOR TENDERS	2
SECTION II	INSTRUCTIONS TO TENDERERS	4
SECTION III	CONDITIONS OF CONTRACT	11
	APPENDIX TO CONDITIONS OF CONTRACT	21 - 22
SECTION IV	SPECIFICATIONS, DRAWINGS AND BILLS OF QUANTITIES/SCHEDULE OF RATES.....	23
SECTION V	STANDARD FORMS	25

SECTION I: INVITATION FOR TENDERS

Tender No. : WRA/T/11/2019-2020

Tender Name: **CONSTRUCTION OF TWO (2) NO. DJABIA'S AT MATONDONI AND KIPUNGANI PRIMARY SCHOOLS IN LAMU ISLAND**

- 1.1 WRA invites sealed tender for **Construction of Two (2) No. Djabia's at Matondoni and Kipungani Primary Schools in Lamu Island**
- 1.2 A complete set of tender documents may be obtained **free of charge** from our website www.wra.go.ke/downloads or PPIP portal: www.tenders.go.ke
- 1.3 Completed tender documents are to be enclosed in plain sealed envelopes marked with tender reference number and be deposited in the Tender Box at NHIF Building, Wing B, 10th floor or to be addressed to **Chief Executive Officer, Water Resources Authority (WRA) P.O.BOX 45250-00100 Nairobi** so as to be received on or before **29th April, 2020 At 11.00am**
- 1.4 Prices quoted should be net inclusive of all taxes and delivery must be in Kenya Shillings and shall remain valid for (120) days from the closing date of the tender.
- 1.5 Tenders will be opened immediately thereafter in the presence of the Candidates or their representatives who choose to attend at SCM Boardroom 10th floor wing B, NHIF, building

Jane Kiyai
For. Chief Executive Officer, Water Resources Authority

SECTION II: INSTRUCTIONS TO TENDERERS

TABLE OF CONTENTS

CLAUSE	PAGE
1. GENERAL -----	4
2. TENDER DOCUMENTS -----	5
3. PREPARATION OF TENDERS -----	5 - 6
4. SUBMISSION OF TENDERS -----	6 - 7
5. TENDER OPENING AND EVALUATION -----	7 - 8
6. AWARD OF CONTRACT -----	8 - 9

1.0 General

- 1.2 The Employer as defined in the Appendix to Conditions of Contract invites tenders for **Construction of Two (2) No. Djabia's at Matondoni and Kipungani Primary Schools in Lamu Island** as described in the tender documents. The successful Tenderer will be expected to complete the Works by the Intended Completion Date specified in the said Appendix.
- 1.3 Tenderers shall include the following **Statutory/Mandatory requirements** information and documents with their tenders:
- 1) Certified Company Registration/incorporation Certificate
 - 2) Certified copy of Current CR12/BN form whichever is applicable
 - 3) Certified Kenya Revenue Authority PIN Certificate
 - 4) Certified Kenya Revenue Authority Valid Tax Compliance Certificate
 - 5) Valid Certificate of registration with National Construction Authority (NCA) Water works
 - 6) Certified Valid Business Trading License Permit from County Government
 - 7) Original Tender security of **Kshs 105,000 (One Hundred and five Thousand Kenya Shillings)** in form of Insurance Bond/Bank Guarantee from financial institution recognized by PPRA valid for 150 days from the Tender submission dateline.
 - 8) Submission of Two bid documents (clearly marked '**original**' and '**copy**') Well bound and correctly serialized / paginated.
 - 9) Correctly duly filled and signed Form of Tender.
- 1.4 The Tenderer, at the Tenderer's own responsibility and risk, is encouraged to visit and examine the Site of the Works and its surroundings, and obtain all information that may be necessary for preparing the tender and entering into a contract for construction of the Works. The costs of visiting the Site shall be at the Tenderer's own expense.
- 1.5 WRA employees, committee members, board members and their relative (spouse and children) are not eligible to participate in the tender.
- 1.6 The price to be charged for the tender document shall not exceed Kshs.1,000/=
- 1.7 WRA shall allow the tenderer to review the tender document free of charge before purchase.

2. Tender Documents

- 2.1 The complete set of tender documents comprises the documents listed here below and any addenda issued in accordance with clause 2.4 here below:-
- (a) These instructions to Tenderers
 - (b) Form of Tender
 - (c) Conditions of Contract and Appendix to Conditions of Contract
 - (d) Specifications
 - (e) Drawings

- (f) Bills of Quantities/Schedule of Rates (whichever is applicable)
- (g) Other materials required to be filled and submitted in accordance with these Instructions and Conditions

- 2.2 The Tenderer shall examine all instructions, forms and specifications in the tender documents. Failure to furnish all information required by the tender documents may result in rejection of his tender.
- 2.3 Prospective Tenderer making inquiries of the tendering documents may notify the Employer in writing or by email, at the address indicated in the letter of invitation to tender. The Employer will respond to any request for clarification received earlier than three [3] days prior to the deadline for submission of tenders. Copies of the Employer's response will be forwarded to all persons issued with tendering documents, including a description of the inquiry, but without identifying its source.
- 2.4 Before the deadline for submission of tenders, the Employer may modify the tendering documents by issuing addenda. Any addendum thus issued shall be part of the tendering documents and shall be communicated in writing or by email to all Tenderers. Prospective Tenderers shall acknowledge receipt of each addendum in writing to the Employer.
- 2.5 To give prospective Tenderers reasonable time in which to take an addendum into account in preparing their tenders, the Employer shall extend, as necessary, the deadline for submission of tenders in accordance with clause 4.2 here below.

3. Preparation of Tenders

- 3.1 All documents relating to the tender and any correspondence shall be in English Language.
- 3.2 The tender submitted by the Tenderer shall comprise the following:-
 - (a) The Tender;
 - (b) Priced Bill of Quantities/Schedule of Rates for lump-sum Contracts
 - (c) Any other materials required to be completed and submitted by Tenderers.
- 3.3 The Tenderer shall fill in rates and prices for all items of the Works described in the Bill of Quantities/Schedule of Rates. Items for which no rate or price is entered by the Tenderer will not be paid for when executed and shall be deemed covered by the other rates and prices in the Bill of Quantities/Schedule of Rates. All duties, taxes and other levies payable by the Contractor under the Contract, as of 30 days prior to the deadline for submission of tenders, shall be included in the tender price submitted by the Tenderer.
- 3.4 The rates and prices quoted by the Tenderer shall not be subject to any adjustment during the performance of the Contract.
- 3.5 The unit rates and prices shall be in Kenya Shillings.

- 3.6 Tenders shall remain valid for a period of Ninety (90) days from the date of submission. However in exceptional circumstances, the Employer may request that the Tenderers extend the period of validity for a specified additional period. The request and the Tenderers' responses shall be made in writing.
- 3.7 The Tenderer shall prepare one original of the documents comprising the tender documents as described in these Instructions to Tenderers.
- 3.8 The original shall be typed or written in indelible ink and shall be signed by a person or persons duly authorized to sign on behalf of the Tenderer. All pages of the tender where alterations or additions have been made shall be initialed by the person or persons signing the tender.
- 3.9 Clarification of tenders shall be requested by the tenderer to be received by the WRA not later than 3 days prior to the deadline for submission of tenders.
- 3.10 WRA shall reply to any clarifications sought by the tenderer within 1 day of receiving the request to enable the tenderer to make timely submission of its tender.

4. Submission of Tenders

- 4.1 The tender duly filled and sealed in an envelope shall;-
 - (a) Be addressed to the Employer at the address provided in the invitation to tender;
 - [b] Bear the name and identification number of the Contract as defined in the invitation to tender; and
 - [c] Provide a warning not to open before the specified time and date for tender opening.
- 4.2 Tenders shall be delivered to the Employer at the address specified above not later than the time and date specified in the invitation to tender.
- 4.3 The tenderer shall not submit any alternative offers unless they are specifically required in the tender documents.

Only one tender may be submitted by each tenderer. Any tenderer who fails to comply with this requirement will be disqualified.
- 4.4 Any tender received after the deadline for opening tenders will be returned to the tenderer un-opened.
- 4.5 The Employer may extend the deadline for submission of tenders by issuing an amendment in accordance with sub-clause 2.5 in which case all rights and obligations of the Employer and the Tenderers previously subject to the original deadline will then be subject to the new deadline.

5. Tender Opening and Evaluation

- 5.1 The tenders will be opened in the presence of the Tenderers' representatives who choose to attend at the time and in the place specified in the invitation to tender.
- 5.2 The Tenderers' names, the total amount of each tender and such other details as may be considered appropriate, will be announced at the opening by the Employer. Minutes of the tender opening, including the information disclosed to those present will also be prepared by the Employer.
- 5.3 Information relating to the examination, clarification, evaluation and comparison of tenders and recommendations for the award of the Contract shall not be disclosed to Tenderers or any other persons not officially concerned with such process until the award to the successful Tenderer has been announced. Any effort by a Tenderer to influence the Employer's officials, processing of tenders or award decisions may result in the rejection of his tender.
- 5.4 Tenders determined to be substantially responsive will be checked for any arithmetic errors. Errors will be corrected as follows:
 - (a) where there is a discrepancy between the amount in figures and the amount in words, the amount in words will prevail; and
 - (b) Where there is a discrepancy between the unit rate and the line item total resulting from multiplying the unit rate by the quantity, the unit rate as quoted will prevail, unless in the opinion of the Employer's representative, there is an obvious typographical error, in which case the adjustment will be made to the entry containing that error.
 - (c) In the event of a discrepancy between the tender amount as stated in the Form of Tender and the corrected tender figure in the main summary of the Bill of Quantities/Quotation, the amount as stated in the Form of Tender shall prevail.
 - (d) The Error Correction Factor shall be computed by expressing the difference between the tender amount and the corrected tender sum as a percentage of the Corrected Builder's Work (i.e. corrected tender sum less P.C. and Provisional Sums).
 - (e) The Error Correction Factor shall be applied to all Builder's Work (as a rebate or addition as the case may be) for the purposes of valuations for Interim Certificates and valuation of variations.
 - (f) The amount stated in the tender will be adjusted in accordance with the above procedure for the correction of errors and with concurrence of the Tenderer, shall be considered as binding upon the Tenderer. If the Tenderer does not accept the corrected amount, the tender may be rejected and the Tender Security forfeited.
- 5.5 The tender evaluation committee shall evaluate the tender within 30 days of the validity period from the date of opening the tender.

- 5.6 Contract price variations shall not be allowed for contracts not exceeding one year (12 months)
- 5.7 Where contract price variation is allowed, the valuation shall not exceed 15% of the original contract price.
- 5.8 Price variation requests shall be processed by the WRA within 30 days of receiving the request.
- 5.9 Preference where allowed in the evaluation of tenders shall not exceed 15%
- 5.10 To assist in the examination, evaluation, and comparison of tenders, the Employer at his discretion, may request [in writing] any Tenderer for clarification of the tender, including breakdowns of unit rates. The request for clarification and the response shall be in writing or by email but no change in the tender price or substance of the tender shall be sought, offered or permitted.
- 5.11 The Tenderer shall not influence the Employer on any matter relating to his tender from the time of the tender opening to the time the Contract is awarded. Any effort by the Tenderer to influence the Employer or his employees in his decision on tender evaluation, tender comparison or Contract award may result in the rejection of the tender.

6. Award of Contract

- 6.1 The award of the Contract will be made to the Tenderer who has offered the lowest evaluated tender price.
- 6.2 Notwithstanding the provisions of clause 6.1 above, the Employer reserves the right to accept or reject any tender and to cancel the tendering process and reject all tenders at any time prior to the award of Contract without thereby incurring any liability to the affected Tenderer or Tenderers or any obligation to inform the affected Tenderer or Tenderers of the grounds for the action.
- 6.3 The Tenderer whose tender has been accepted will be notified of the award prior to expiration of the tender validity period in writing or by cable, telex or facsimile. This notification (hereinafter and in all Contract documents called the "Letter of Acceptance") will state the sum [hereinafter and in all Contract documents called the "Contract Price" which the Employer will pay the Contractor in consideration of the execution, completion, and maintenance of the Works by the Contractor as prescribed by the Contract. The contract shall be formed on the parties signing the contract. At the same time the other tenderers shall be informed that their tenders have not been successful.
- 6.4 The Contract Agreement will incorporate all agreements between the Employer and the successful Tenderer. It will be signed by the Employer and sent to the successful Tenderer, within 30 days following the notification of award. Within 14 days of receipt, the successful Tenderer will sign the Agreement and return it to the Employer.

- 6.5 Within 7 days after receipt of the Letter of Acceptance, the successful Tenderer shall deliver to the Employer a Performance Security amount stipulated in the Appendix to Conditions of Contract.
- 6.6 The parties to the contract shall have it signed within 30 days from the date of notification of contract award unless there is an administrative review request.
- 6.7 WRA may at any time terminate procurement proceedings before contract award and shall not be liable to any person for the termination.
- 6.8 WRA shall give prompt notice of the termination to the tenderers and on request give its reasons for termination within 14 days of receiving the request from any tenderer.

7. Corrupt and fraudulent practices

- 7.1 WRA requires that the tenderer observes the highest standard of ethics during the procurement process and execution of the contract. A tenderer shall sign a declaration that he has not and will not be involved in corrupt and fraudulent practices.
- 7.2 WRA will reject a tender if it determines that the tenderer recommended for award has engaged in corrupt and fraudulent practices in competing for the contract in question.
- 7.3 Further a tenderer who is found to have indulged in corrupt and fraudulent practices risks being debarred from participating in public procurement in Kenya.

SECTION III: CONDITIONS OF CONTRACT

	Table of Clauses	Page
1.	DEFINITIONS.....	11
2.	CONTRACT DOCUMENTS.....	12
3.	EMPLOYER’S REPRESENTATIVE’S DECISIONS.....	13
4.	WORKS, LANGUAGE AND LAW OF CONTRACT.....	13
5.	SAFETY, TEMPORARY WORKS AND DISCOVERIES.....	13
6.	WORK PROGRAM AND SUB-CONTRACTING.....	13
7.	THE SITE.....	13 - 14
8.	INSTRUCTIONS.....	14
9.	EXTENSION OF COMPLETION DATE.....	14 - 15
10.	MANAGEMENT MEETINGS.....	15
11.	DEFECTS.....	15 - 16
12.	BILLS OF QUANTITIES/SCHEDULE OF RATES.....	16
13.	VARIATIONS.....	16
14.	PAYMENT CERTIFICATES AND FINAL ACCOUNT	16 - 17
15.	INSURANCES	18
16.	LIQUIDATED DAMAGES.....	18
17.	COMPLETION AND TAKING OVER.....	18
18.	TERMINATION.....	18 - 19
19.	PAYMENT UPON TERMINATION.....	19
20.	CORRUPT GIFTS AND PAYMENTS OF COMMISSION.....	19 - 20
21.	SETTLEMENT OF DISPUTES.....	20
22.	APPENDIX TO CONDITIONS OF CONTRACT	21 – 22

SECTION III - CONDITIONS OF CONTRACT

1. Definitions

1.1 In this Contract, except where context otherwise requires, the following terms shall be interpreted as indicated;

“Bills of Quantities” means the priced and completed Bill of Quantities forming part of the tender [where applicable].

“Schedule of Rates” means the priced Schedule of Rates forming part of the tender [where applicable].

“The Completion Date” means the date of completion of the Works as certified by the Employer’s Representative.

“The Contract” means the agreement entered into by the Employer and the Contractor as recorded in the Agreement Form and signed by the parties.

“The Contractor” refers to the person or corporate body whose tender to carry out the Works has been accepted by the Employer.

“The Contractor’s Tender” is the completed tendering document submitted by the Contractor to the Employer.

“The Contract Price” is the price stated in the Letter of Acceptance.

“Days” are calendar days; **“Months”** are calendar months.

“A Defect” is any part of the Works not completed in accordance with the Contract.

“The Defects Liability Certificate” is the certificate issued by Employer’s Representative upon correction of defects by the Contractor.

“The Defects Liability Period” is the period named in the Appendix to Conditions of Contract and calculated from the Completion Date.

“Drawings” include calculations and other information provided or approved by the Employer’s Representative for the execution of the Contract.

“Employer” Includes Central or Local Government administration, Universities, Public Institutions and Corporations and is the party who employs the Contractor to carry out the Works.

“Equipment” is the Contractor’s machinery and vehicles brought temporarily to the Site for the execution of the Works.

“Site” means the place or places where the permanent Works are to be carried out including workshops where the same is being prepared.

“Materials” are all supplies, including consumables, used by the Contractor for incorporation in the Works.

“Employer’s Representative” is the person appointed by the Employer and notified to the Contractor for the purpose of supervision of the Works.

“Specification” means the Specification of the Works included in the Contract.

“Start Date” is the date when the Contractor shall commence execution of the Works.

“A Subcontractor” is a person or corporate body who has a Contract with the Contractor to carry out a part of the Work in the Contract, which includes Work on the Site.

“Temporary works” are works designed, constructed, installed, and removed by the Contractor which are needed for construction or installation of the Works.

“A Variation” is an instruction given by the Employer’s Representative which varies the Works.

“The Works” are what the Contract requires the Contractor to construct, install, and turnover to the Employer.

2. Contract Documents

2.1 The following documents shall constitute the Contract documents and shall be interpreted in the following order of priority;

- (1) Agreement,
- (2) Letter of Acceptance,
- (3) Contractor’s Tender,
- (4) Conditions of Contract,
- (5) Specifications,
- (6) Drawings,
- (7) Bills of Quantities or Schedule of Rates [whichever is applicable]

3. Employer’s Representative’s Decisions

3.1 Except where otherwise specifically stated, the Employer’s Representative will decide contractual matters between the Employer and the Contractor in the role representing the Employer.

4. Works, Language and Law of Contract

4.1 The Contractor shall construct and install the Works in accordance with the Contract documents. The Works may commence on the Start Date and shall be carried out in accordance with the Program submitted by the Contractor, as updated with the approval of the Employer’s Representative, and complete them by the Intended Completion Date.

- 4.2 The ruling language of the Contract shall be English language and the law governing the Contract shall be the law of the Republic of Kenya.

5. Safety, Temporary works and Discoveries

- 5.1 The Contractor shall be responsible for design of temporary works and shall obtain approval of third parties to the design of the temporary works where required.
- 5.2 The Contractor shall be responsible for the safety of all activities on the Site.
- 5.3 Anything of historical or other interest or significant value unexpectedly discovered on the Site shall be the property of the Employer. The Contractor shall notify the Employer's Representative of such discoveries and carry out the Employer's Representative's instructions for dealing with them.

6 Work Program and Sub-contracting

- 6.1 Within seven days after Site possession date, the Contractor shall submit to the Employer's Representative for approval a program showing the general methods, arrangements, order and timing for all the activities in the Works.
- 6.2 The Contractor may sub-contract the Works (but only to a maximum of 25 percent of the Contract Price) with the approval of the Employer's Representative. However, he shall not assign the Contract without the approval of the Employer in writing. Sub-contracting shall not alter the Contractor's obligations.

7 The site

- 7.1 The Employer shall give possession of all parts of the Site to the Contractor.
- 7.2 The Contractor shall allow the Employer's Representative and any other person authorized by the Employer's Representative, access to the Site and to any place where work in connection with the Contract is being carried out or is intended to be carried out.

8 Instructions

- 8.1 The Contractor shall carry out all instructions of the Employer's Representative which are in accordance with the Contract.

9 Extension of Completion Date

- 9.1 The Employer's Representative shall extend the Completion Date if an occurrence arises which makes it impossible for completion to be achieved by the Intended Completion Date. The Employer's Representative shall decide whether and by how much to extend the Completion Date.
- 9.2 For the purposes of this clause, the following occurrences shall be valid for consideration;

Delay by:-

- (a) force majeure, or
- (b) reason of any exceptionally adverse weather conditions, or
- (c) reason of civil commotion, strike or lockout affecting any of the trades employed upon the Works or any of the trades engaged in the preparation, manufacture or transportation of any of the goods or materials required for the Works, or
- (d) reason of the Employer's Representative's instructions issued under these Conditions, or
- (e) reason of the contractor not having received in due time necessary instructions, drawings, details or levels from the Employer's Representative for which he specifically applied in writing on a date which having regard to the date for Completion stated in the appendix to these Conditions or to any extension of time then fixed under this clause was neither unreasonably distant from nor unreasonably close to the date on which it was necessary for him to receive the same, or
- (f) delay on the part of artists, tradesmen or others engaged by the Employer in executing work not forming part of this Contract, or
- (g) reason of delay by statutory or other services providers or similar bodies engaged directly by the Employer, or
- (h) reason of opening up for inspection of any Work covered up or of the testing or any of the Work, materials or goods in accordance with these conditions unless the inspection or test showed that the Work, materials or goods were not in accordance with this Contract, or
- (i) reason of delay in appointing a replacement Employer's Representative, or
- (j) reason of delay caused by the late supply of goods or materials or in executing Work for which the Employer or his agents are contractually obliged to supply or to execute as the case may be, or
- (k) Delay in receiving possession of or access to the Site.

10 Management Meetings

- 10.1 A Contract management meeting shall be held regularly and attended by the Employer's Representative and the Contractor. Its business shall be to review the plans for the remaining Work. The Employer's Representative shall record the business of management meetings and provide copies of the record to those attending the meeting and the Employer. The responsibility of the parties for actions to be taken shall be decided by the Employer's Representative either at the management meeting or after the management meeting and stated in writing to all who attend the meeting.

10.2 Communication between parties shall be effective only when in writing.

11 Defects

11.1 The Employer's Representative shall inspect the Contractor's work and notify the Contractor of any defects that are found. Such inspection shall not affect the Contractor's responsibilities. The Employer's Representative may instruct the Contractor to search for a defect and to uncover and test any Work that the Employer's Representative considers may have a defect. Should the defect be found, the cost of uncovering and making good shall be borne by the Contractor. However if there is no defect found, the cost of uncovering and making good shall be treated as a variation and added to the Contract Price.

11.2 The Employer's Representative shall give notice to the Contractor of any defects before the end of the Defects Liability Period, which begins at Completion, and is defined in the Appendix to Conditions of Contract.

11.3 Every time notice of a defect is given, the Contractor shall correct the notified defect within the length of time specified by the Employer's Representative's notice. If the Contractor has not corrected a defect within the time specified in the Employer's Representative's notice, the Employer's Representative will assess the cost of having the defect corrected by other parties and such cost shall be treated as a variation and be deducted from the Contract Price.

12 Bills of Quantities/Schedule of Rates

12.1 The Bills of Quantities/Schedule of Rates shall contain items for the Work to be done by the Contractor. The Contractor will be paid for the quantity of the Work done at the rates in the Bills of Quantities/Schedule of Rates for each item. Items against which no rate is entered by the Tenderer will not be paid for when executed and shall be deemed covered by the rates for other items in the Bills of Quantities/Schedule of Rates.

12.2 Where Bills of Quantities do not form part of the Contract, the Contract Price shall be a lump sum (which shall be deemed to have been based on the rates in the Schedule of Rates forming part of the tender) and shall be subject to re-measurement after each stage.

13 Variations

13.1 The Contractor shall provide the Employer's Representative with a quotation for carrying out the variations when requested to do so. The Employer's Representative shall assess the quotation and shall obtain the necessary authority from the Employer before the variation is ordered.

13.2 If the Work in the variation corresponds with an item description in the Bill of Quantities/Schedule of Rates, the rate in the Bill of Quantities/Schedule of Rates shall be used to calculate the value of the variation. If the nature of the Work in the variation does not correspond with items in the Bill of Quantities/Schedule of Rates, the quotation by the Contractor shall be in the form of new rates for the relevant items of Work.

- 13.3 If the Contractor's quotation is unreasonable, the Employer's Representative may order the variation and make a change to the Contract Price, which shall be based on the Employer's Representative's own forecast of the effects of the variation on the Contractor's costs.

14 Payment Certificates and Final Account

- 14.1 The Contractor shall be paid after each of the following stages of Work listed here below (subject to re-measurement by the Employer's Representative of the Work done in each stage before payment is made). In case of lump-sum Contracts, the valuation for each stage shall be based on the quantities so obtained in the re-measurement and the rates in the Schedule of Rates.

(Phase payment)

- 14.2 Upon deciding that Works included in a particular stage are complete, the Contractor shall submit to the Employer's Representative his application for payment. The Employer's Representative shall check, adjust if necessary and certify the amount to be paid to the Contractor within 21 days of receipt of the Contractor's application. The Employer shall pay the Contractor the amounts so certified within 30 days of the date of issue of each Interim Certificate.
- 14.3 The Contractor shall supply the Employer's Representative with a detailed final account of the total amount that the Contractor considers payable under the Contract before the end of the Defects Liability Period. The Employer's Representative shall issue a Defect Liability Certificate and certify any final payment that is due to the Contractor within 30 days of receiving the Contractor's account if it is correct and complete. If it is not, the Employer's Representative shall issue within 21 days a schedule that states the scope of the corrections or additions that are necessary. If the final account is still unsatisfactory after it has been resubmitted, the Employer's Representative shall decide on the amount payable to the Contractor and issue a Final Payment Certificate. The Employer shall pay the Contractor the amount so certified within 60 days of the issue of the Final Payment Certificate.
- 14.4 If the period laid down for payment to the Contractor upon each of the Employer's Representative's Certificate by the Employer has been exceeded, the Contractor shall be entitled to claim simple interest calculated pro-rata on the basis of the number of days delayed at the Central Bank of Kenya's average base lending rate prevailing on the first day the payment becomes overdue. The Contractor will be required to notify the Employer within 15 days of receipt of delayed payments of his intentions to claim interest.

15. Insurance

- 15.1 The Contractor shall be responsible for and shall take out appropriate cover against, among other risks, personal injury; loss of or damage to the Works, materials and plant; and loss of or damage to property.

16. Liquidated Damages

16.1 The Contractor shall pay liquidated damages to the Employer at the rate 0.001 per cent of the Contract price per day for each day that the actual Completion Date is later than the Intended Completion Date except in the case of any of the occurrences listed under clause 9.2. The Employer may deduct liquidated damages from payments due to the Contractor. Payment of liquidated damages shall not affect the Contractor's liabilities.

17. Completion and Taking Over

17.1 Upon deciding that the Work is complete the Contractor shall request the Employer's Representative to issue a Certificate of Completion of the Works, upon deciding that the Work is completed.

The Employer shall take over the Site and the Works within seven days of the Employer's Representative issuing a Certificate of Completion.

18. Termination

18.1 The Employer or the Contractor may terminate the Contract if the other party causes a fundamental breach of the Contract. These fundamental breaches of Contract shall include, but shall not be limited to, the following;

- (a) the Contractor stops Work for 30 days continuously without reasonable cause or authority from the Employer's Representative;
- (b) the Contractor is declared bankrupt or goes into liquidation other than for a reconstruction or amalgamation;
- (c) a payment certified by the Employer's Representative is not paid by the Employer to the Contractor within 30 days after the expiry of the payment periods stated in sub clauses 14.2 and 14.3 hereinabove.
- (d) The Employer's Representative gives notice that failure to correct a particular defect is a fundamental breach of Contract and the Contractor fails to correct it within a reasonable period of time.

18.2 If the Contract is terminated, the Contractor shall stop Work immediately, and leave the Site as soon as reasonably possible. The Employer's Representative shall immediately thereafter arrange for a meeting for the purpose of taking record of the Works executed and materials, goods, equipment and temporary buildings on Site.

19. Payment Upon Termination

19.1 The Employer may employ and pay other persons to carry out and complete the Works and to rectify any defects and may enter upon the Works and use all materials on Site, plant, equipment and temporary works.

19.2 The Contractor shall, during the execution or after the completion of the Works under this clause, remove from the Site as and when required within such reasonable time as the Employer's Representative may in writing specify,

any temporary buildings, plant, machinery, appliances, goods or materials belonging to him, and in default thereof, the Employer may (without being responsible for any loss or damage) remove and sell any such property of the Contractor, holding the proceeds less all costs incurred to the credit of the Contractor.

- 19.3 Until after completion of the Works under this clause, the Employer shall not be bound by any other provision of this Contract to make any payment to the Contractor, but upon such completion as aforesaid and the verification within a reasonable time of the accounts therefor the Employer's Representative shall certify the amount of expenses properly incurred by the Employer and, if such amount added to the money paid to the Contractor before such determination exceeds the total amount which would have been payable on due completion in accordance with this Contract, the difference shall be a debt payable to the Employer by the Contractor; and if the said amount added to the said money be less than the said total amount, the difference shall be a debt payable by the Employer to the Contractor.

20. Corrupt Gifts and Payments of Commission

20.1 The Contractor shall not;

- (a) Offer or give or agree to give to any person in the service of the Employer any gifts or consideration of any kind as an inducement or reward for doing or forbearing to do or for having done or forborne to do any act in relation to the obtaining or execution of this or any other contract with the Employer or for showing or forbearing to show favour or disfavor to any person in relation to this or any other contract with the Employer.
- (b) Any breach of this Condition by the Contractor or by anyone employed by him or acting on his behalf (whether with or without the knowledge of the Contractor) shall be an offence under the Laws of Kenya.

21. Settlement of Disputes

- 21.1 Any dispute arising out of the Contract which cannot be amicably settled between the parties shall be referred by either party to the arbitration and final decision of a person to be agreed between the parties. Failing agreement to concur in the appointment of an Arbitrator, the Arbitrator shall be appointed by the chairman of the Chartered Institute of Arbitrators, Kenya branch, on the request of the applying party.

APPENDIX TO CONDITIONS OF CONTRACT

THE EMPLOYER IS

Name: **Water Resources Authority (WRA) P.O.BOX 45250 00100** Name of Employer's

Representative:

Title:

Telephone:

The name & No. of the Contract is **Construction of Two (2) No. Djabia's at Matondoni and Kipungani Primary Schools in Lamu Island - WRA/T/11/2019-2020**

The Works consist of **Construction of Two (2) No. Djabia's at Matondoni and Kipungani Primary Schools in Lamu Island**

The Start Date shall be **May 2020**

The Intended Completion Date for the whole of the Works shall be on **June 2020**

The following documents also form part of the Contract:

- (i) Letter of Acceptance
- (ii) Acknowledgement Letter Accepting Available to Work With Budget
- (iii) Procuring entity's Notification of Award
- (iv) Form of Tender
- (v) General Conditions of Contract
- (vi) Drawings
- (vii) Priced Bills of Quantities

The Site Possession Date shall be on

The Site is located

The Defects Liability Period is

Amount of Tender Security should be between one (1) percent and two (2) percent of the value of the Works)

The name and Address of the Employer for the purposes of submission of tenders NHIF Building, Wing B, 10th floor or to be addressed to **Chief Executive Officer, Water Resources Authority (WRA) P.O.BOX 45250 00100**

SECTION IV – SPECIFICATIONS, DRAWINGS AND BILLS OF QUANTITIES/SCHEDULE OF RATES

1 BACKGROUND INFORMATION

Introduction

Water is one of Kenya’s most important of natural resources, being a basic necessity for livelihoods, ecosystems, social and economic activities. The Constitution of Kenya (2010) recognizes water as a human right, while under Vision 2030; water is identified as an essential resource to support the country’s development agenda. Further, the Constitution espouses the “Protection of the environment and natural resources with a view to establishing a durable and sustainable system of development”. In lieu of this, the Government of Kenya recently enacted Water Act 2016, which under Section 63, stipulates that “every person in Kenya has the right to clean and safe water in adequate quantities and to reasonable standards of sanitation as stipulated in Article 43 of the Constitution”. These instruments are meant to give the water sector renewed impetus to support the country’s technological, social and economic development. The sector has to reform yet again given that Kenya has a devolved system of Government; there are emerging issues such as increasing demand for water, industrialization, climate change, as well as the need for safeguarding the environment and water resources.

The Water Resources Authority (WRA) is a national institution under the Ministry of Water and Sanitation. The Authority was established under the Water Act 2016 to regulate the management and use of water resources and ensure equitable allocation of water resources to all users. The Authority executes these functions countrywide through its six regional offices within respective basin areas as guided by the National Water Resources Management Strategy (NWRMS). The NWRMS provides a framework based on which Basin Management Strategies are developed.

WRA through Tana water Catchment Area has been carrying Lamu Groundwater Conservation to protect and secure sand dunes aquifer for sustainable supply of fresh water in Lamu Island which is threatened by seawater intrusion and encroachment since 2010. The project outcome is to ensure that the groundwater resources are secured and recharge area completely protected from encroachment.

One of these will be implementation of the Amu conservation plan by undertaking the following Amu WRUA activities:-

1. Construction of Djabia in Matondoni Primary School
2. Construction of Djabia in Kipungani

The Terms of Reference (ToR) outlined below have been generated for the purpose of procuring construction services for 2No. Djabias.

Legal context

(i) Constitution of Kenya

COK 2010 Constitution of Kenya 2010 recognizes water as a human right and confers to every person the right to clean and safe water in adequate quantities in a clean and healthy

environment. Consequently, water resources have drawn national attention where it has been recognized as being essential in making the country become industrialized in accordance to the Kenya's Vision 2030, a blue print for the national development agenda for Kenya

Section 62 (1) public land is (l) all land between high and low water marks

Section 66 of the constitution deals with land and provides that the State may regulate the use of any land, or any interest in or right over any land, in the public interest.

Section 69 deals with the environment and natural resources including the sustainable exploitation, utilization, management and conservation and the equitable sharing of the accruing benefits. It is also the duty of every person to co-operate with State organs and other persons to protect and conserve the environment and ensure ecologically sustainable development and use of natural resources.

(ii) Water Act, 2016

Section 22(1)

Provides that where the Authority is satisfied that in order to conserve a vulnerable water resource, special measures are necessary for the protection of catchment area or part thereof, it may, by order published in the Gazette declare such a catchment area to be a protected area.

Section 22(2)

Provides that The Authority may impose such requirements, or regulate or prohibit such conduct or activities, in or in relation to a protected area as the Authority may consider necessary to impose, regulate or prohibit for the protection of the catchment area and its water resources.

Under Sections 23 of the Act, the Authority may identify a catchment area, part of a catchment area or water resource to be identified as areas to be Protected or designated as Groundwater Conservation Areas if the Authority is satisfied that doing so is necessary for the protection of the water resource and its multiple uses. The Authority shall, in conjunction with relevant institutions and stakeholders, establish management rules or plans that shall apply to each Protected Area or Groundwater Conservation Area.

(iii) Water Resources Management Rules 2007

Part III section 52. (1) Any portion of land in excess of one hectare which is naturally subject to seasonal or permanent flooding and has the ecological characteristics of a swamp or marsh shall be a wetland under these Rules.

Part III section 52. (2) The Authority may by Public Notification and with good cause, declare any portion of land less than one hectare as a wetland for purposes of water resources management.

Part XI section 123-126 provides for protected areas and groundwater conservation areas including management guidelines related to a protected area or a ground water conservation area.

The Authority shall also undertake Public Consultation with respect to the establishment of areas to be Protected or designated as Groundwater Conservation Areas and the management rules or plans that shall apply with respect to these Areas.

OBJECTIVES OF THE PROJECT

The main objective of the conservation project is to protect and harvest rain water to supplement conserved ground water in the sand dunes. The construction shall be conducted as outlined in the scope of works. Thus, the project aims to achieve the following specific objectives:

1. To construct djabias to collect fresh rain water from roof tops and concrete constructed catchment.
2. To construct underground storage tank to store harvested roof and constructed catchment water.

SCOPE OF WORKS

The scope of works will comprise the following: –

1. Construction of Djabias at
 - a) Matondoni Primary School,
 - b) Kipungani

METHODOLOGY

The project activities will generally be undertaken under the following methodology; excavation works, concrete works for foundation and reinforcements, walling, roofing, smooth finishes, auxiliary works for djabia construction.

Djabia Construction

Excavation works

1. This will be done to the sloping induced catchments for a depth not less than 300mm but not more than 1.5m with dimensions 8.8m x 22.5m
2. 2m dept 8m diameter for the underground tank or as directed by the engineer.

Concrete works and reinforcements

This will be about 100mm high for catchment and reinforcement's 250c/c spacing of Y8, bars 300c/c spacing of Y10/12, 200mmc/c spacing of Y8, both for foundation and roof slabs for the tank.

Walling and smooth finishes

Building blocks of size 300mm x 100mm will be used for construction where mortar of ration 1:3 to be placed between joints followed by plastering and smooth finishes with water proofing well applied to the walls and floors both for the tank and catchments.

Auxiliary works

This consists of construction of pump base, extraction platform, connecting gutters to roof tops, installation of pump, connecting of water supply pipe.

Tools and Equipment

Unless directed otherwise most tools used will be at most 220D excavator and hand tools for both skilled and unskilled labour mostly used in construction.

REPORTING AND DURATION OF THE PROJECT

The construction of djabias is expected to take three months from the date of signing of the contract. The contractor shall give (Site handing over, progress and completion) reports to the supervisor during the construction period.

OUTPUTS

The key outputs of the assignment will include;

- 1) 2 No Djabias water and harvesting systems constructed according to the designs.
- 2) Completion reports.

QUALIFICATIONS AND EXPERIENCE

Experience of the Contracted Firm

The construction firm must have conducted similar works. Work experience in coastal areas will be an added advantage. A proof of this including the references of the respective clients must be provided in the tender document. The construction firm must be licensed by a recognized institution in Kenya. Thus, the firm:

- 1) must be eligible and possess the necessary permits and licences to undertake this kind of work in Kenya
- 2) must have a good knowledge of the terrain of Coastal Kenya
- 3) must demonstrate capacity to construct the djabias
- 4) must demonstrate capacity to produce high quality works;
- 5) must demonstrate possession of experience of undertaking such projects.

QUALIFICATIONS AND EXPERIENCE OF KEY STAFF

The contractor's team for the assignment shall be composed of qualified and experienced professionals. The Contractors firm is required to propose a site agent who reflects an appropriate civil engineering education, skills and levels of experience, a sound understanding of all aspects of construction management and a demonstrated regional experience on similar projects. The site agent should have engineering background and should be readily available at the site especially during execution of the activities.

STATEMENT OF THE DUTIES AND RESPONSIBILITIES OF THE CLIENT

The Client represented by the Engineer will be responsible to support the successful contractor during the project period by:

- i. Introducing the contractor to interested parties and stakeholders;
- ii. Giving instructions to the contractor during the period.
- iii. Monitoring and supervising the project implementation;
- iv. Reviewing, validating and compiling of submitted project reports by contractor
- v. Recommending certificate of payments

- vi. Any other assistance that might be required by the contractor to ensure successful project run.

CONTRACTOR'S FEES AND PAYMENTS

The contractor's fees are specified in the contract document which is paid in terms of percentage where he will prepare for the certificate of payment which must be evaluated by the Engineer before payment.

A. BILLS OF QUANTITIES/SCHEDULE OF RATES – MATONDONI - DJABIA

PROJECT NAME	MATONDONI-DJABIA FOR AMU WRUA				
SUBJECT	DJABIA CONSTRUCTION/ BILL OF QUANTITIES.				
Item	Description	Unit	Qty	Rate	Amount
1.	Preliminaries				00
1.1	Mobilization/ Demobilization allow provisional sum to cater for mobilization/ demobilization.	Item	L/S		
2	Earth works				
2.1	Clear site of trees, tree stumps, shrubs and grass commencing from ground level n.e 300mm deep and dispose off.	M ²	274.6		
2.2	Commence reservoir excavation from stripped level and deposit not less than 10m away as directed by Engineer on site and Haulage be done later	M ³	133.50		
2.2.1	Excavate on hard rock	M ³	12		
2.3	Remove and haul the excavated material	M ³	145.5		
2.4	Backfill the work area after construction and compact	M ³	95.90		
2.5	Excavation of catchment foundation not exceeding 1.5m	M ³	105.5		
3.0	Hardcore filling				
3.1	300mm thick hardcore filling into the catchment area	M ³	61.35		
3.2	Hardcore filling into the bottom of the tank	M ³	19.10		
3.3	50mm thick murrum blinding	M ³	4.1		
4.0	CONCRETE WORKS: Vibrated concrete.				
4.1	50mm thick concrete class 15 mix 1:3:6 placed to receive reinforced concrete (ground floor of the tank	M ³	3.2		

PROJECT NAME	MATONDONI-DJABIA FOR AMU WRUA				
SUBJECT	DJABIA CONSTRUCTION/ BILL OF QUANTITIES.				
Item	Description	Unit	Qty	Rate	Amount
4.1	0.1m thick concrete class 25 mix 1:1.5: 3 floor of underground tank	M ³	6.8		
4.2	250 x 250 concrete class 25 mix 1: 1.5:3 ring beam to receive concrete roof	M ³	2.8		
4.3	0.1m thick reinforced concrete class 20 mix 1: 2: 4 roof. of underground tank	M ³	5.67		
4.4	Concrete class 20 mix 1:2: 4 for the catchment	M ³	20.50		
5.0	Walling				
5.1	500mm Thick masonry walling in cement and sand mortar (1:3)	M ²	56.52		
5.2	225mm Thick masonry walling in cement and sand mortar (1:3)	M ²	50.24		
5.3	200mm Thick masonry walling in cement and sand mortar (1:3)	M ²	225.5		
5.4	Y-8 reinforcement bars	Rm	672		
6.0	Form work				
6.1	Well sawn timber 1 x 8 inch Cyprus timber, 2 x 3 inch Cyprus timber and nails.	M ²	70		
6.2	Round poles	No	100		
7.0	Finishes				
7.1	25mm thick Cement and sand mortar (1:3) plaster on the walls.	M ²	161.50		
7.2	12 mm Thick plaster mixed with Sika or equivalent water proofing admixture	M ²	50.24		
7.3	25mm thick Cement and sand mortar (1:3) plaster on the and floors	M ²	297.24		
8.0	Pipe				
8.1	100mm diameter PVC overflow pipe class D	No	1		
8.2	75mm diameter PVC overflow pipe 800mm long	No	1		

PROJECT NAME	MATONDONI-DJABIA FOR AMU WRUA				
SUBJECT	DJABIA CONSTRUCTION/ BILL OF QUANTITIES.				
Item	Description	Unit	Qty	Rate	Amount
8.3	75mm diameter drain pipe 800mm long	No			
8.4	50mm diameter draw off pipe Class B GI	No	1		
8.5	50mm diameter brass gate valve with wheel and head	No	1		
9.0	Inspection				
9.1	600x600x6mm medium gauge steel primed metal manhole cover on slab with and including metal framing all around	No	1		
9.2	20mm Diameter bars, 'U' shaped to form steps with ends embedded into retaining wall, average length 450mm	No	8		
10	Fencing				
10.1	Fencing concrete poles 0.15m x 0.1m	No	14		
10.2	Barbed wire	Roll	2		
10.3	Chain-link	Roll	5		
10.4	Concrete (hole, dia = 0.5 depth= 1m) mix 1:3:6	M ³	3.4		
10.5	Hole digging	M ³	3.2		
11	Pump				
11.1	India MarkII hand pump	No	1		
12	Water Collection point				
12.1	Excavation of 1.5 x 2m x 0.4	m ³	1.5		
12.3	Hardcore filling	M ³	1.0		
12.3	Concrete works	M ³	0.8		
13.0	Water collection				
13.1	Gutters	No	14		
13.2	Collection	No	6		
13.3	Extension plastic pipes 3" class D 6m length pipes	No.	6		
	Sub-total				
	Supervision 10% Labour 10%, transport and contingency cost 10% (For WRA staff and contractor's labour)				

PROJECT NAME	MATONDONI-DJABIA FOR AMU WRUA				
SUBJECT	DJABIA CONSTRUCTION/ BILL OF QUANTITIES.				
Item	Description	Unit	Qty	Rate	Amount
	16% Value Added Tax (VAT)				
	Grand Total				

DRAWINGS / DESIGN (Attached)

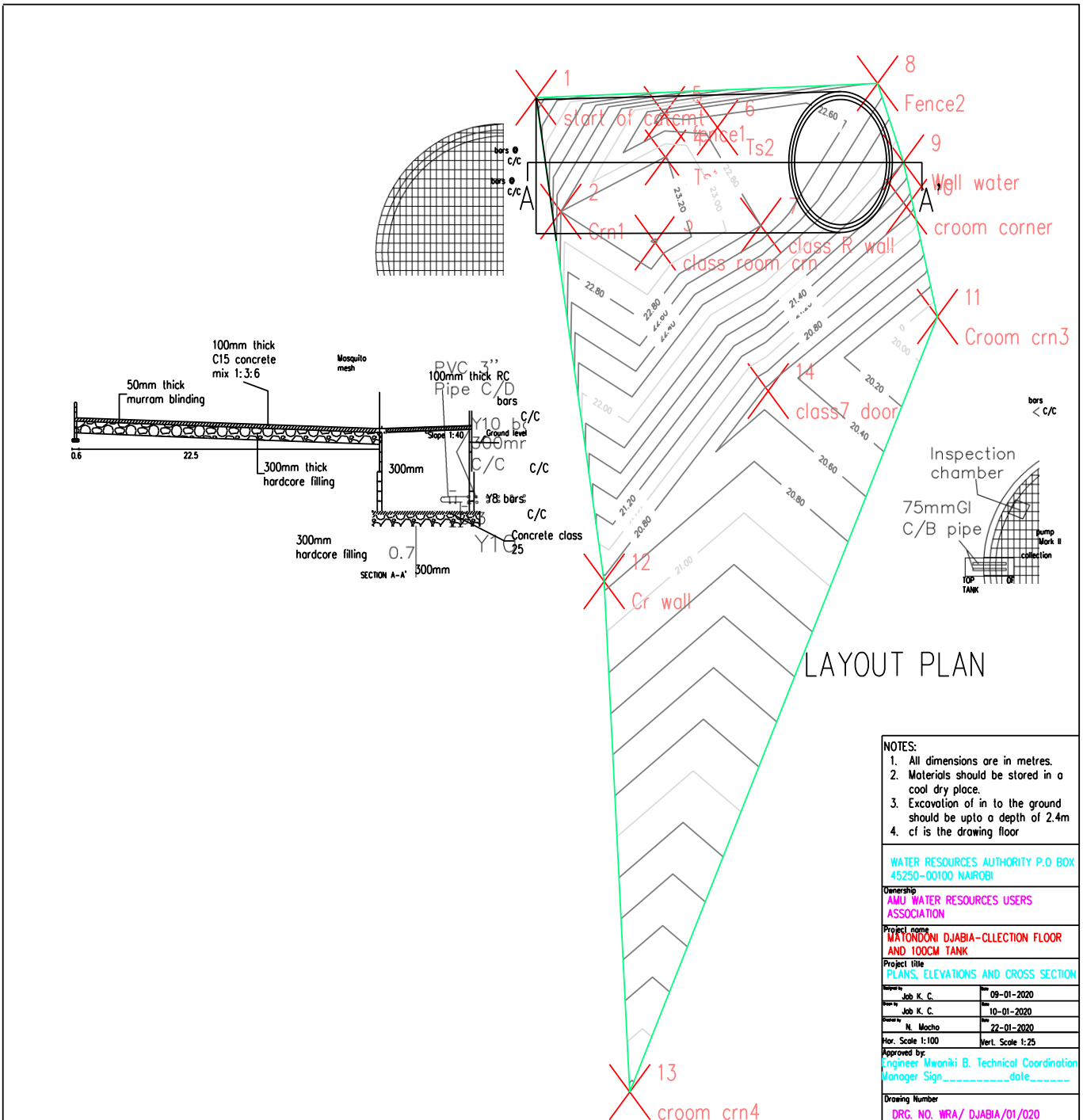

B. BILLS OF QUANTITIES/SCHEDULE OF RATES - KIPUNGANI DJABIA

PROJECT NAME	KIPUNGANI DJABIA FOR AMU-WRUA				
SUBJECT	DJABIA CONSTRUCTION/ BILL OF QUANTITIES.				
Item	Description	unit	Qty	Rate	Amount
1.	Preliminaries				00
1.1	Mobilization/ Demobilization allow provisional sum to cater for mobilization/ demobilization.	Item	L/S		
2	Earth works				
2.1	Clear site of trees, tree stumps, shrubs and grass commencing from ground level n.e 300mm deep and dispose off.	M ²	206		
2.2	Commence reservoir excavation from stripped level and deposit not less than 10m away as directed by Engineer on site and Haulage be done later	M ³	167.80		
2.2.1	Excavate on hard rock	M ³	10		
2.3	Remove and haul the excavated material	M ³	200.26		
2.4	Backfill the work area after construction and compact	M ³	48.8		
2.5	Excavation of catchment foundation not exceeding 1.5m	M ³	61.50		
3.0	Hardcore filling				
3.1	300mm thick hardcore filling into the catchment area	M ³	24.64		
3.2	Hardcore filling into the bottom of the tank	M ³	61.8		
3.3	50mm thick murrum blinding	M ³	4.1		
4.0	CONCRETE WORKS: Vibrated concrete.				
4.1	50mm thick concrete class 15 mix 1:3:6 placed to receive reinforced concrete (ground floor of the tank	M ³	3.2		
4.1	0.1m thick concrete class 25 mix 1:1.5: 3 floor of underground tank	M ³	6.8		
4.2	250 x 250 concrete class 25 mix 1: 1.5:3 ring beam to receive concrete roof	M ³	2.8		
4.3	0.1m thick reinforced concrete class 20 mix 1: 2: 4 roof. of underground tank	M ³	5.67		
4.4	Concrete class 20 mix 1:2: 4 for the catchment	M ³	20.6		
5.0	Walling				

PROJECT NAME	KIPUNGANI DJABIA FOR AMU-WRUA				
SUBJECT	DJABIA CONSTRUCTION/ BILL OF QUANTITIES.				
Item	Description	unit	Qty	Rate	Amount
5.1	500mm Thick masonry walling in cement and sand mortar (1:3)	M ²	56.52		
5.2	225mm Thick masonry walling in cement and sand mortar (1:3)	M ²	25.12		
5.3	200mm Thick masonry walling in cement and sand mortar (1:3)	M ²	25		
5.4	Y-8 reinforcement bars	Rm	672		
6.0	Form work				
6.1	Well sawn timber 1 x 8 inch Cyprus timber, 2 x 3 inch Cyprus timber and nails.	M ²	70		
6.2	Round poles	No	100		
7.0	Finishes				
7.1	Cement and sand mortar (1:3) plaster in:	M ²	52		
7.2	12 mm Thick plaster mixed with Sika or equivalent water proofing admixture	M ²	78		
8.0	Pipe				
8.1	100mm diameter PVC overflow pipe class D	No	1		
8.2	75mm diameter PVC overflow pipe 800mm long	No	1		
8.3	75mm diameter drain pipe 800mm long	No			
8.4	50mm diameter draw off pipe Class B GI	No	1		
8.5	50mm diameter brass gate valve with wheel and head	No	1		
9.0	Inspection				
9.1	600x600x6mm medium gauge steel primed metal manhole cover on slab with and including metal framing all around	No	1		

PROJECT NAME	KIPUNGANI DJABIA FOR AMU-WRUA				
SUBJECT	DJABIA CONSTRUCTION/ BILL OF QUANTITIES.				
Item	Description	unit	Qty	Rate	Amount
9.2	20mm Diameter bars, 'U' shaped to form steps with ends embedded into retaining wall, average length 450mm	No	8		
10	Fencing				
10.1	Fencing concrete poles 0.15m x 0.1m	No	16		
10.2	Barbed wire	Roll	2		
10.3	Chainlink	Roll	5		
10.4	Concrete(hole, dia = 0.5 depth= 1m) mix 1:3:6	M ³	3.4		
10.5	Hole digging	M ³	3.2		
11	Pump				
11.1	India MarkII hand pump	No	1		
12	Water Collection point				
12.1	Excavation of 1.5 x 2m x 0.4	m ³	1.5		
12.3	Hardcore filling	M ³	1.0		
12.3	Concrete works	M ³	0.8		
13.0	Water collection				
13.1	Gutters	No	14		
13.2	Collection	No	6		
13.3	Extension plastic pipes 3" class D 6m length pipes	No.	6		
	Sub-total				
	Supervision 15% Labour 10%, Transport and Contingency cost 10%				
	16% Value Added Tax (VAT)				
	Grand Total				

DRAWINGS / DESIGN

(Attached)

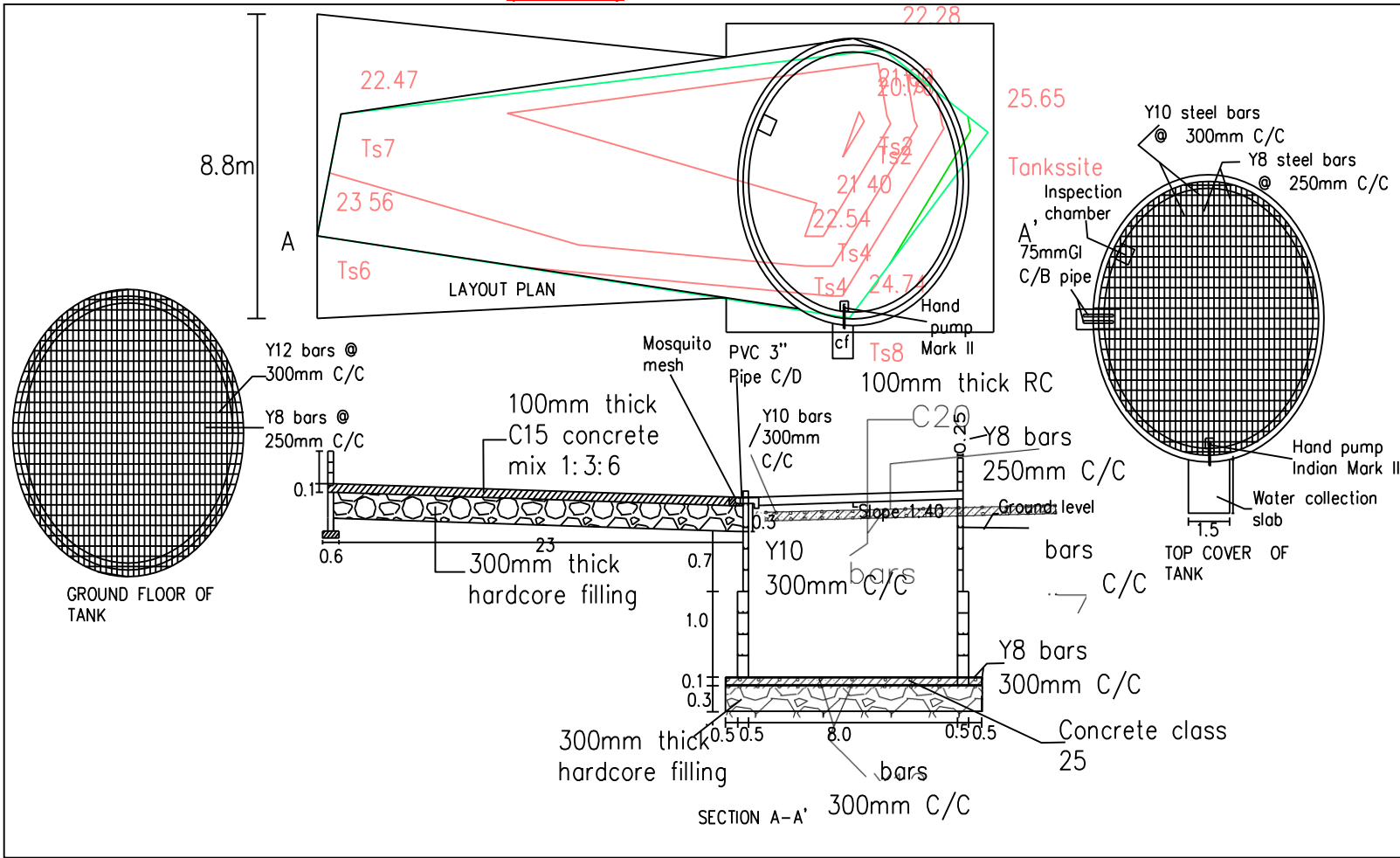

- NO S:
1. All dimensions are in metres.
 2. Materials should be stored in a cool dry place.
 3. Excavation of in to the ground should be upto a depth of 2.4m
 4. cf is the drawing floor

WA R RESOURCES AU ORITY P.O BOX
45250-00100 NAIROBI

Ownership
AMU WA R RESOURCES USERS
ASSOCIATION

Project name
KIPUNGANI PRIMARY SCHOOL DJABIA
CLECTION FLOOR AND 100CM TANK

Project title
PLANS, VATIONS AND CROSS SECTION

Designed by Job K. C.	Date 23-12-2019
Designed by Job K. C.	Date 23-12-2019
Designed by N. Mocho	Date 24-12-2019
Hor. Scale 1:100	Vert. Scale 1:25

Approved by:
Engineer Mwaniki B. Technical Coordination
Manager Sign_____date_____

Drawing Number
DRG. NO.3 WRA-AMU/ DJABIA/12/019

TENDER EVALUATION CRITERIA

After tender opening, the tenders shall be evaluated in 2 stages, namely:

1. Determination of Responsiveness
2. Financial Evaluation.

STAGE 1- DETERMINATION OF RESPONSIVENESS

A) PRELIMINARY EXAMINATION

This stage of evaluation shall involve examination of the pre-qualification conditions as set out in the Tender Advertisement Notice or Letter of Invitation to Tender and any other conditions stated in the bid document.

Mandatory Documents (Statutory requirements).

- 1) Certified Company Registration/incorporation Certificate
- 2) Certified copy of Current CR12/BN form whichever is applicable
- 3) Certified Kenya Revenue Authority PIN Certificate
- 4) Certified Kenya Revenue Authority Valid Tax Compliance Certificate
- 5) Valid Certificate of registration with National Construction Authority (NCA) Water works
- 6) Certified Valid Business Trading License Permit from County Government
- 7) Original Tender security of Kshs 105,000 (One Hundred and five Thousand Kenya Shillings) in form of Insurance Bond/Bank Guarantee from financial institution recognized by PPRA valid for 150 days from the Tender submission dateline.
- 8) Submission of Two bid documents (clearly marked 'original' and 'copy') Well bound and correctly serialized / paginated.
- 9) Correctly duly filled and signed Form of Tender.

Note: The tenderers who do not satisfy any of the above requirements shall be considered Non- Responsive and their tenders will not be evaluated further.

B) TECHNICAL EVALUATION

The tender document shall be examined based on the Instruction to Tenderers which states as follows:

In accordance with Instruction to Tenderers, the tenderers will be required to provide evidence for eligibility of the award of the tender by satisfying the employer of their eligibility and adequacy of resources to effectively carry out the subject contract. The tenderer shall be required to fill the Standards Forms provided for the purposes of providing the required information. The tenderers may also attach the required information if they so desire.

The award of points in this section shall be as shown below;		
PARAMETER		MAXIMUM POINTS
(i) Statement of Compliance		2
(ii) Tender Questionnaire		2
(iii) Confidential Business Questionnaire		2

(iv) Key personnel		30
(v) Contract Completed in the last one (1) year		18
(vi) Schedules of on-going projects		10
(vii) Schedules of contractors equipment		20
(viii) Audited Financial Report for the last 1 year		5
(ix) Evidence of Financial Resources		5
(x) Name, Address and Telephone of Banks (Contractor to provide)		2
(xii) Sanctity of the tender document as in accordance		4
	Total	100

Measurement Parameters for Scoring plan shall be as shown below: -

Item	Description	Point Scored	Max.Point
i	Statement of Compliance Signed and stamped ----- 2 Signed but not stamped or vice versa-----1 Not signed nor stamped -----0		2
ii	Tender Questionnaire Form Completely filled -----2 Partially filled -----1 Not filled -----0		2
iii	Confidential Business Questionnaire Form. Completely filled ----- 2 Partially filled ----- 1 Not filled ----- 0		2
vii	Key Personnel to be engaged on the project (Attach copies of certificates) Site Supervisor o Minimum Diploma in water Engineering/Building & construction/civil engineering----- 30 o Certificate-----15 o No relevant certificate -----0		30
v	Contract completed in the last one(1) year(max of 2 No. Projects) Shall attach Completion Certificates. Demonstrated Experience of the Firm as a prime contractor in the construction with at least a demonstration having completed two project Project of similar nature, complexity and magnitude -----(2x9) Project of similar nature but of lower value than the one in consideration----- (1x9) No completed project of similar nature ----- 0		18

vi	On-going project (A max of 1 No. Project) Shall attach Notification of award or Contract Agreement. Project of similar nature, complexity and magnitude ----- (10) Project of similar nature but of lower value than the one in consideration ----- (5) No ongoing project of similar nature -----0		10
vii	Schedules of contractor's Equipment like Excavator/Dosser/ Mixers/Lorries. Shall attach proof or evidence of ownership by the company, if owned or and indicate the ability to lease (Attach letter from the less or if leased) Owned----- (20) Leased ----- (15) Not provided----- (0)		20
viii	Annual Audited financial reports(last one(3)year) Financial year 2017/2018 At least the annual turnover greater or equal to the cost of the project ----- (5) Annual turn-over below the cost of the project--- (0)		5
x	Name, Address, Email and telephone of Contractor. Provided (2) Not provided (0)		2
Xii	Sanctity of tender documents Having the document intact(not tampered with in any way) -- 4 Having mutilated or modified the tender document--- 0		4
	TOTAL TECHNICAL SCORE (TS)		100

The pass Mark for technical score is 70points therefore any bidder who scores 70 points and above shall be considered for Financial evaluation

STAGE 2 -FINANCIAL EVALUATION

The bid shall be checked for arithmetic errors based on the rates and the total sums indicated in the bills of quantities and There shall be no correction of errors according to the PPADA 2015 (82).

RECOMMENDATION

The evaluation committee shall recommend for award of the **Tender** to the tenderer with the lowest evaluated price from among those which are eligible, compliant and substantially responsive.

SECTION V : STANDARD FORMS

List of Standard Forms

- (i) Form of Invitation for Tenders
- (ii) Form of Tender
- (iii) Letter of Acceptance
- (iv) Form of Agreement
- (v) Form of Tender Security
- (vi) Performance Bank Guarantee
- (vii) Performance Bond
- (viii) Bank Guarantee for Advance Payment
- (ix) Qualification Information
- (x) Tender Questionnaire
- (xi) Confidential Business Questionnaire
- (xii) Details of Sub-Contractors
- (xiii) Request for Review Form

FORM OF INVITATION FOR TENDERS

15th April 2020

To:
.....
.....
.....

Dear Sir/ Madam:

REFERENCE: WRA/T/11/2019-2020; Construction of Two (2) No. Djabia’s at Matondoni and Kipungani Primary Schools in Lamu Island

You have been prequalified to tender for the above project.

We hereby invite you and other prequalified tenderers to submit a tender for the execution and completion of the above Contract.

A complete set of tender documents may be obtained by invited candidates upon payment of non-refundable fees of **Ksh 1,000 (One thousand)** in cash or Bankers cheque payable to Chief Executive Officer Water Resources Management Authority. Alternatively, tender document can be obtained by invited candidates **free of charge** from our *website* www.wra.go.ke/downloads or *PIIP portal*: www.tenders.go.ke

Completed tender documents are to be enclosed in plain sealed envelopes marked with tender reference number and be deposited in the Tender Box at NHIF Building, Wing B, 10th floor or to be addressed to **Chief Executive Officer, Water Resources Authority (WRA)** **P.O.BOX 45250 00100** so as to be received on or before **29th April, 2020 At 11.00am**

Tenders will be opened immediately thereafter in the presence of the candidates or their representatives who choose to attend at the boardroom

Please confirm receipt of this letter immediately in writing by cable/facsimile or telex.

Yours faithfully,

Jane Kiyai
For. Chief Executive Officer, Water Resources Authority

FORM OF TENDER

TO: _____ [Name of Employer] _____ [Date]

_____ [Name of Contract]

Dear Sir,

1. In accordance with the Conditions of Contract, Specifications, Drawings and Bills of Quantities/Schedule of Rates for the execution of the above named Works, we, the undersigned offer to construct, install and complete such Works and remedy any defects therein for the sum of Kshs. _____ [Amount in figures] Kenya Shillings _____ [Amount in words]
2. We undertake, if our tender is accepted, to commence the Works as soon as is reasonably possible after the receipt of the Employer's Representative's notice to commence, and to complete the whole of the Works comprised in the Contract within the time stated in the Appendix to Conditions of Contract.
3. We agree to abide by this tender until _____ [Insert date], and it shall remain binding upon us and may be accepted at any time before that date.
4. Unless and until a formal Agreement is prepared and executed this tender together with your written acceptance thereof, shall constitute a binding Contract between us.
5. We understand that you are not bound to accept the lowest or any tender you may receive.

Dated this _____ day of _____ 20 _____

Signature _____ in the capacity of _____

duly authorized to sign tenders for and on behalf of
_____ [Name of Tenderer] of
_____ [Address of Tenderer]

Witness; Name _____

Address _____

Signature _____

Date _____

(Amend accordingly if provided by Insurance Company)

LETTER OF ACCEPTANCE
[letter head paper of the Employer]

_____ [date]

To: _____
[name of the Contractor]

[address of the Contractor]

Dear Sir,

This is to notify you that your Tender dated _____
for the execution of _____
[name of the Contract and identification number, as given in the Tender documents] for the
Contract Price of Kshs. _____ [amount in figures][Kenya
Shillings _____ (amount in words)] in accordance with the
Instructions to Tenderers is hereby accepted.

You are hereby instructed to proceed with the execution of the said Works in accordance with
the Contract documents.

Authorized Signature

Name and Title of Signatory

Attachment : Agreement

FORM OF AGREEMENT

THIS AGREEMENT, made the _____ day of _____ 20 _____ between _____ of [or whose registered office is situated at] _____ (hereinafter called “the Employer”) of the one part AND _____ of [or whose registered office is situated at] _____ (hereinafter called “the Contractor”) of the other part.

WHEREAS THE Employer is desirous that the Contractor executes

_____ (*name and identification number of Contract*) (hereinafter called “the Works”) located at _____ [*Place/location of the Works*] and the Employer has accepted the tender submitted by the Contractor for the execution and completion of such Works and the remedying of any defects therein for the Contract Price of Kshs _____ [*Amount in figures*], Kenya Shillings _____ [*Amount in words*].

NOW THIS AGREEMENT WITNESSETH as follows:

1. In this Agreement, words and expressions shall have the same meanings as are respectively assigned to them in the Conditions of Contract hereinafter referred to.
2. The following documents shall be deemed to form and shall be read and construed as part of this Agreement i.e.
 - (viii) Letter of Acceptance
 - (ix) Form of Tender
 - (x) Conditions of Contract Part I
 - (xi) Conditions of Contract Part II and Appendix to Conditions of Contract
 - (xii) Specifications
 - (xiii) Drawings
 - (xiv) Priced Bills of Quantities/Priced Schedule of Rates [whichever is applicable]
3. In consideration of the payments to be made by the Employer to the Contractor as hereinafter mentioned, the Contractor hereby covenants with the Employer to execute and complete the Works and remedy any defects therein in conformity in all respects with the provisions of the Contract.

4. The Employer hereby covenants to pay the Contractor in consideration of the execution and completion of the Works and the remedying of defects therein, the Contract Price or such other sum as may become payable under the provisions of the Contract at the times and in the manner prescribed by the Contract.

IN WITNESS whereof the parties thereto have caused this Agreement to be executed the day and year first before written.

The common Seal of _____

Was hereunto affixed in the presence of _____

Signed Sealed, and Delivered by the said _____

Binding Signature of Employer _____

Binding Signature of Contractor _____

In the presence of (i) Name _____

Address _____

Signature _____

[ii] Name _____

Address _____

Signature _____

FORM OF TENDER SECURITY

WHEREAS(hereinafter called “the Tenderer”) has submitted his tender dated for the construction of
..... (name of Contract)

KNOW ALL PEOPLE by these presents that WE having our registered office at(hereinafter called “the Bank”), are bound unto(hereinafter called “the Employer”) in the sum of Kshs..... for which payment well and truly to be made to the said Employer, the Bank binds itself, its successors and assigns by these presents sealed with the Common Seal of the said Bank this Day of20.....

THE CONDITIONS of this obligation are:

If after tender opening the tenderer withdraws his tender during the period of tender validity specified in the instructions to tenderers
Or

If the tenderer, having been notified of the acceptance of his tender by the Employer during the period of tender validity:

- (a) fails or refuses to execute the form of Agreement in accordance with the Instructions to Tenderers, if required; or
- (b) fails or refuses to furnish the Performance Security, in accordance with the Instructions to Tenderers;

We undertake to pay to the Employer up to the above amount upon receipt of his first written demand, without the Employer having to substantiate his demand, provided that in his demand the Employer will note that the amount claimed by him is due to him, owing to the occurrence of one or both of the two conditions, specifying the occurred condition or conditions.

This guarantee will remain in force up to and including thirty (30) days after the period of tender validity, and any demand in respect thereof should reach the Bank not later than the said date.

[date]

[signature of the Bank]

[witness]

[seal]

PERFORMANCE BANK GUARANTEE

To: _____ (Name of Employer) _____ (Date)
_____ (Address of Employer)

Dear Sir,

WHEREAS _____ (hereinafter called "the Contractor") has undertaken, in pursuance of Contract No. _____ dated _____ to execute _____ (hereinafter called "the Works");

AND WHEREAS it has been stipulated by you in the said Contract that the Contractor shall furnish you with a Bank Guarantee by a recognized bank for the sum specified therein as security for compliance with his obligations in accordance with the Contract;

AND WHEREAS we have agreed to give the Contractor such a Bank Guarantee:

NOW THEREFORE we hereby affirm that we are the Guarantor and responsible to you, on behalf of the Contractor, up to a total of Kshs. _____ (*amount of Guarantee in figures*) Kenya Shillings _____ (*amount of Guarantee in words*), and we undertake to pay you, upon your first written demand and without civil or argument, any sum or sums within the limits of Kenya Shillings _____ (*amount of Guarantee in words*) as aforesaid without your needing to prove or to show grounds or reasons for your demand for the sum specified therein.

We hereby waive the necessity of your demanding the said debt from the Contractor before presenting us with the demand.

We further agree that no change, addition or other modification of the terms of the Contract or of the Works to be performed thereunder or of any of the Contract documents which may be made between you and the Contractor shall in any way release us from any liability under this Guarantee, and we hereby waive notice of any change, addition, or modification.

This guarantee shall be valid until the date of issue of the Certificate of Completion.

SIGNATURE AND SEAL OF THE GUARANTOR _____

Name of Bank _____

Address _____

Date _____

(Amend accordingly if provided by Insurance Company)

PERFORMANCE BOND

By this Bond, We _____ of (or whose registered office is situated at] _____ as Principal (hereinafter called "the Contractor") and _____ of [or whose registered office is situated at] _____ as Surety (hereinafter called "the Surety"), are held and firmly bound unto _____ of [or whose registered office is situated at] _____

As Oblige (hereinafter called "the Employer") in the amount of Kshs. _____ [amount of Bond in figures] Kenya Shillings

_____ [amount of Bond in words], for the payment of which sum well and truly, the Contractor and the Surety bind themselves, their heirs, executors, administrators, successors and assigns, jointly and severally, firmly by these presents.

WHEREAS the Contractor has entered into a Contract with the Employer dated the _____ day of _____ 20 _____ for the execution of

_____ [name of Contract] in accordance with the Contract documents, Specifications and amendments thereto, which to the extent herein provided for, are by reference made part hereof and are hereinafter referred to as the Contract.

NOW THEREFORE, the Condition of this Obligation is such that, if the Contractor shall promptly and faithfully perform the said Contract (including any amendments thereto), then this obligation shall be null and void; otherwise it shall remain in full force and effect. Whenever the Contractor shall be, and declared by the Employer to be, in default under the Contract, the Employer having performed the Employer's obligations thereunder, the Surety may promptly remedy the default, or shall promptly:

- (1) complete the Contract in accordance with its terms and conditions; or
- (2) obtain a tender or tenders from qualified tenderers for submission to the Employer for completing the Contract in accordance with its terms and conditions, and upon determination by the Employer and the Surety of the lowest responsive tenderer, arrange for a Contract between such tenderer and Employer and make available as work progresses (even though there should be a default or a succession of defaults under the Contract or Contracts of completion arranged under this paragraph) sufficient funds to pay the cost of completion less the balance of the Contract Price; but not exceeding, including other costs and damages for which the Surety may be liable hereunder, the amount set forth in the first paragraph hereof.

The term "Balance of the Contract Price", as used in this paragraph, shall mean the total amount payable by the Employer to the Contractor under the

Contract, less the amount properly paid by the Employer to the Contractor; or

(3) pay the Employer the amount required by the Employer to complete the Contract in accordance with its terms and conditions up to a total not exceeding the amount of this Bond.

The Surety shall not be liable for a greater sum than the specified penalty of this Bond.

Any suit under this Bond must be instituted before the expiration of one year from the date of issuance of the Certificate of Completion.

No right of action shall accrue on this Bond to or for the use of any person or corporation other than the Employer named herein or the heirs, executors, administrators, successors and assigns of the Employer.

In testimony whereof, the Contractor has hereunto set his hand and affixed his seal, and the Surety has caused these presents to be sealed with his corporate seal duly attested by the signature of his legal representative, this _____ day of _____ 20_____

SIGNED ON _____ SIGNED ON _____

On behalf of _____ On behalf of _____
[name of Contractor] *[name of Surety]*

By _____ By _____

In the capacity of _____ In the capacity of _____

In the presence of;Name _____ In the presence of;Name _____

Address _____

Address _____

Signature _____

Signature _____

Date _____

Date _____

BANK GUARANTEE FOR ADVANCE PAYMENT

To: _____ *[name of Employer]* _____ *(Date)*
_____ *[address of Employer]*

Gentlemen,

Ref: _____ *[name of Contract]*

In accordance with the provisions of the Conditions of Contract of the above-mentioned Contract, We, _____ *[name and Address of Contractor]* (hereinafter called "the Contractor") shall deposit with _____ *[name of Employer]* a bank guarantee to guarantee his proper and faithful performance under the said Contract in an amount of Kshs. _____ *[amount of Guarantee in figures]* Kenya Shillings _____ *[amount of Guarantee in words]*.

We, _____ *[bank or financial institution]*, as instructed by the Contractor, agree unconditionally and irrevocably to guarantee as primary obligator and not as Surety merely, the payment to _____ *[name of Employer]* on his first demand without whatsoever right of objection on our part and without his first claim to the Contractor, in the amount not exceeding Kshs _____ *[amount of Guarantee in figures]* Kenya Shillings _____ *[amount of Guarantee in words]*, such amount to be reduced periodically by the amounts recovered by you from the proceeds of the Contract.

We further agree that no change or addition to or other modification of the terms of the Contract or of the Works to be performed thereunder or of any of the Contract documents which may be made between _____ *[name of Employer]* and the Contractor, shall in any way release us from any liability under this guarantee, and we hereby waive notice of any such change, addition or modification.

No drawing may be made by you under this guarantee until we have received notice in writing from you that an advance payment of the amount listed above has been paid to the Contractor pursuant to the Contract.

This guarantee shall remain valid and in full effect from the date of the advance payment under the Contract until _____ *(name of Employer)* receives full payment of the same amount from the Contract.

Yours faithfully,

Signature and Seal _____

Name of the Bank or financial institution _____

Address _____

Date _____

Witness: Name: _____

Address: _____

Signature: _____

Date: _____

QUALIFICATION INFORMATION

1. Individual Tenderers or Individual Members of Joint Ventures

1.1 Constitution or legal status of tenderer (attach copy or Incorporation Certificate);

Place of registration: _____

Principal place of business _____

Power of attorney of signatory of tender _____

1.2 Total annual volume of construction work performed in the last five years

Year	Volume	
	Currency	Value

1.3 Work performed as Main Contractor on works of a similar nature and volume over the last five years. Also list details of work under way or committed, including expected completion date.

Project name	Name of client and contact person	Year of completion	Type of work performed and Value of Contract
_____	_____	_____	_____
_____	_____	_____	_____
_____	_____	_____	_____

1.4 Major items of Contractor's Equipment proposed for carrying out the Works. List all information requested below.

Item of Equipment	Description, Make and age (years)	Condition (new, good, poor) and number available	Owned, leased (from whom?), or to be purchased (from whom?)
_____	_____	_____	
_____ (etc	_____	_____	
.)	_____	_____	

1.5 Qualifications and experience of key personnel proposed for administration and execution of the Contract. Attach biographical data.

Position	Name	Years of experience (general)	Years of experience in proposed position
Project Manager			
_____	_____	_____	_____
_____	_____	_____	_____
_____	_____	_____	_____
(etc.)			

1.6 Financial reports for the last five years: balance sheets, profit and loss statements, auditor's reports, etc. List below and attach copies.

1.7 Evidence of access to financial resources to meet the qualification requirements: cash in hand, lines of credit, etc. List below and attach copies of supportive documents.

1.8 Name, address and telephone, telex and facsimile numbers of banks that may provide reference if contacted by the Employer.

1.9 Statement of compliance with the requirements of Clause 1.2 of the Instructions to Tenderers.

1.10 Proposed program (work method and schedule) for the whole of the Works.

2 Joint Ventures

2.0 The information listed in 1.1 – 2.0 above shall be provided for each partner of the joint venture.

2.1 The information required in 1.11 above shall be provided for the joint venture.

- 2.2 Attach the power of attorney of the signatory(ies) of the tender authorizing signature of the tender on behalf of the joint venture
- 2.3 Attach the Agreement among all partners of the joint venture (and which is legally binding on all partners), which shows that:
- a) all partners shall be jointly and severally liable for the execution of the Contract in accordance with the Contract terms;
 - b) one of the partners will be nominated as being in charge, authorized to incur liabilities and receive instructions for and on behalf of any and all partners of the joint venture; and
 - c) the execution of the entire Contract, including payment, shall be done exclusively with the partner in charge.

TENDER QUESTIONNAIRE

Please fill in block letters.

1. Full names of tenderer;

.....

2. Full address of tenderer to which tender correspondence is to be sent (unless an agent has been appointed below);

.....

3. Telephone number (s) of tenderer;

.....

4. Telex of tenderer;

.....

5. Name of tenderer's representative to be contacted on matters of the tender during the tender period;

.....

6. Details of tenderer's nominated agent (if any) to receive tender notices. This is essential if the tenderer does not have his registered address in Kenya (name, address, telephone, telex);

.....

.....

Signature of Tenderer

Make copy and deliver to: _____ (*Name of Employer*)

CONFIDENTIAL BUSINESS QUESTIONNAIRE

You are requested to give the particulars indicated in Part 1 and either Part 2 (a), 2 (b) or whichever applies to your type of business.

You are advised that it is a serious offence to give false information on this Form.

Part 1 – General

Business Name

Location of business premises; Country/Town.....

Plot No..... Street/Road

Postal Address..... Tel No.....

Nature of Business.....

Current Trade Licence No..... Expiring date.....

Maximum value of business which you can handle at any time: K.
pound.....

Name of your bankers.....

Branch.....

Part 2 (a) – Sole Proprietor

Your name in full..... Age.....

Nationality..... Country of Origin.....

Citizenship details

Part 2 (b) – Partnership

Give details of partners as follows:

	<i>Name in full</i>	<i>Nationality</i>	<i>Citizenship Details</i>	<i>Shares</i>
1
2
3

DETAILS OF SUB-CONTRACTORS

If the Tenderer wishes to sublet any portions of the Works under any heading, he must give below details of the sub-contractors he intends to employ for each portion.

Failure to comply with this requirement may invalidate the tender.

(1) Portion of Works to be sublet:

[i] Full name of Sub-contractor
and address of head office:
.....

[ii] Sub-contractor's experience
of similar works carried out
in the last 3 years with
Contract value:
.....
.....

(2) Portion of Works to sublet:

[i] Full name of sub-contractor
and address of head office:
.....
.....

[ii] Sub-contractor's experience
of similar works carried out
in the last 3 years with
contract value:
.....

[Signature of Tenderer)

Date

LETTER OF NOTIFICATION OF AWARD

Address of WRMA

To: _____

RE: Tender No. _____

Tender Name _____

This is to notify that the contract/s stated below under the above mentioned tender have been awarded to you.

1. Please acknowledge receipt of this letter of notification signifying your acceptance.
2. The contract/contracts shall be signed by the parties within 30 days of the date of this letter but not earlier than 14 days from the date of the letter.
3. You may contact the officer(s) whose particulars appear below on the subject matter of this letter of notification of award.

(FULL PARTICULARS) _____

SIGNED FOR ACCOUNTING OFFICER

REPUBLIC OF KENYA
PUBLIC PROCUREMENT ADMINISTRATIVE REVIEW BOARD

APPLICATION NO.....OF.....20.....

BETWEEN

.....APPLICANT

AND

.....RESPONDENT WRMA

Request for review of the decision of the..... (*Name of the WRMA*) of
.....dated the...day of20.....in the matter of Tender No.....of
.....20...

REQUEST FOR REVIEW

I/We.....,the above named Applicant(s), of address: Physical
address.....Fax No.....Tel. No.....Email, hereby request the Public
Procurement Administrative Review Board to review the whole/part of the above mentioned
decision on the following grounds , namely:-

- 1.
- 2.
- etc.

By this memorandum, the Applicant requests the Board for an order/orders that: -

- 1.
- 2.
- etc

SIGNED(Applicant)

Dated on.....day of/...20...

FOR OFFICIAL USE ONLY

Lodged with the Secretary Public Procurement Administrative Review Board on day
of20.....

SIGNED

Board Secretary